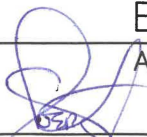

WOODLAND EROSION STANDARDS SHEET INDEX

- 01 SYMBOLS
- 02 SITE EROSION CONTROL
- 03 EROSION PREVENTION AND SEDIMENT CONTROL
- 04 STAKE AND WIRE FENCE
- 05 STABILIZED CONSTRUCTION ENTRANCE
- 06 WHEEL WASH
- 07 NETS AND BLANKETS
- 08 PLASTIC COVERING
- 09 SURFACE ROUGHENING
- 10 GRADIENT TERRACES
- 11 INTERCEPTOR DIKE AND SWALE
- 12 GRASS-LINED CHANNELS
- 13 PIPE SLOPE DRAINS
- 14 LEVEL SPREADER
- 15 CHECK DAM
- 16 INLET PROTECTION (1 OF 2)
- 17 INLET PROTECTION (2 OF 2)
- 18 STRAW BALE BARRIER
- 19 BRUSH BARRIER
- 20 SILT FENCE
- 21 STRAW WATTLES
- 22 SEDIMENT TRAP
- 23 SEDIMENT POND
- 24 SILTATION TRENCH BEHIND CURB

EROSION STANDARDS – SHEET INDEX

	 APPROVED	REVISIONS	DATE	DRAWN	DESIGNED	E-00	
	_____	_____	_____	_____	_____		_____
	PUBLIC WORKS DIRECTOR	DATE					

2/14/02

ELE#	BMP#	TITLE	KEY	SYMBOL
1	C101	PRESERVING NATURAL VEGETATION	VEG	
1	C102	BUFFER ZONES	BZ	
1	C103	HIGH VISIBILITY PLASTIC OR METAL FENCE	HVF	
1	C104	STAKE AND WIRE FENCE	SWF	
2	C105	STABILIZED CONSTRUCTION ENTRANCE	CE	
2	C106	WHEEL WASH	WW	
2	C107	CONSTRUCTION ROAD / PARKING STABILIZATION	CRS	
5, 6	C120	TEMPORARY AND PERMANENT SEEDING	TPS	
5	C121	MULCHING	MU	
5	C122	NETS AND BLANKETS	NET	
5	C123	PLASTIC COVERING	PC	
5	C124	SODDING	SO	
5	C125	TOPSOILING	TO	
5	C126	POLYACRYLAMIDE FOR SOIL EROSION PROTECTION	PAM	
5, 6	C130	SURFACE ROUGHENING	SR	
5, 6	C131	GRADIENT TERRACES	GT	
5	C140	DUST CONTROL	DC	
5,6,8	C150	MATERIALS ON HAND	MOH	WESTERN WASHINGTON SWMM SPECIFICATIONS
9	C151	CONCRETE HANDLING	CH	WESTERN WASHINGTON SWMM SPECIFICATIONS
9	C152	SAWCUTTING AND SURFACING POLLUTION PREVENTION	SAW	WESTERN WASHINGTON SWMM SPECIFICATIONS
2	C160	CONTRACTOR EROSION AND SPILL CONTROL LEAD	SCL	WESTERN WASHINGTON SWMM SPECIFICATIONS
2	C161	PAYMENT OF EROSION CONTROL WORK	PAY	WESTERN WASHINGTON SWMM SPECIFICATIONS

ELE#	BMP#	TITLE	KEY	SYMBOL
5	C162	SCHEDULING	SCH	WESTERN WASHINGTON SWMM SPECIFICATIONS
5	C180	SMALL PROJECT CONSTRUCTION STORMWATER POLLUTION PREVENTION	SMP	CITY OF WOODLAND SPECIFICATIONS
6	C200	INTERCEPTOR DIKE AND SWALE	ID/S	
6	C201	GRASS-LINED CHANNELS	GC	
8	C202	CHANNEL LINING	CL	
5	C203	WATER BARS	WB	
6	C204	PIPE SLOPE DRAIN	PSD	
6	C205	SUBSURFACE DRAINS	SUD	
6	C206	LEVEL SPREADER	LS	
6	C207	CHECK DAMS	CD	
6	C208	TRIANGULAR SILT DIKE (GEOTEXTILE-ENCASED CHECK DAM)	TSD	
8	C209	OUTLET PROTECTION	OP	
7	C220	STORM DRAIN INLET PROTECTION	IP	
4	C230	STRAW BALE BARRIER	STB	
4	C231	BRUSH BARRIER	BB	
4	C232	GRAVEL FILTER BERM	FB	
4	C233	SILT FENCE	SF	
4	C234	VEGETATED STRIP	VS	
4	C235	STRAW WATTLES	SW	
3, 4	C240	SEDIMENT TRAP	ST	
3, 4	C241	TEMPORARY SEDIMENT POND	SP	
4	C250	CONSTRUCTION STORMWATER CHEMICAL TREATMENT	CT	
4	C251	CONSTRUCTION STORMWATER FILTRATION	FIL	

SYMBOLS



APPROVED
 PUBLIC WORKS DIRECTOR DATE 2/14/22

REVISIONS	DATE	DRAWN	DESIGNED

E-01

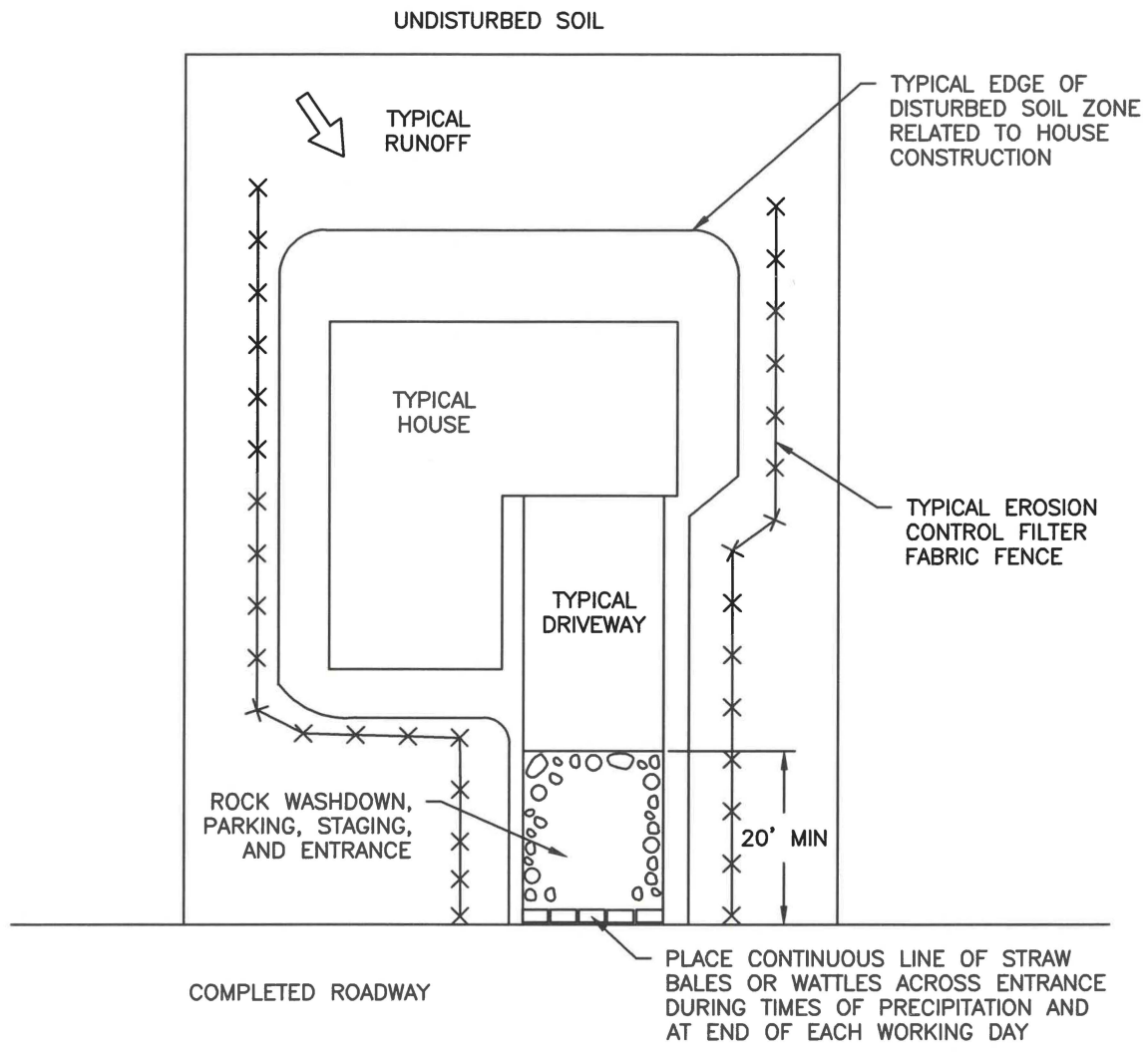

NOTES:

1. DEPENDING UPON CONTRACTORS' PRACTICES, THESE MEASURES MAY BE VARIED WITH APPROVAL FROM THE CITY OF WOODLAND.
2. CONTRACTOR SHALL BE REQUIRED TO CONFORM TO ALL GENERAL EROSION CONTROL NOTES AND DETAILS.
3. DOWNSPOUTS SHALL NOT DRAIN TO THE ROADWAY RIGHT-OF-WAY OR INTO ANY DRAINAGE STRUCTURES IN THE RIGHT-OF-WAY, EXCEPT WHERE APPROVED BY CITY OF WOODLAND.

SITE EROSION CONTROL



APPROVED

 PUBLIC WORKS DIRECTOR
 DATE 2/14/22

REVISIONS	DATE	DRAWN	DESIGNED

E-02

GENERAL EROSION PREVENTION & SEDIMENT CONTROL NOTES

1. ALL EROSION AND SEDIMENT CONTROL MEASURES SHALL BE IN PLACE AND IN WORKING CONDITION PRIOR TO ANY LAND DISTURBING ACTIVITY CAUSED BY CLEARING OR GRADING. EROSION AND SEDIMENT CONTROL MEASURES SHALL BE APPROVED BY THE CITY EROSION CONTROL SPECIALIST PRIOR TO THE COMMENCEMENT OF WORK. THE CONTRACTOR SHALL CALL FOR AN ON-SITE INSPECTION WHEN EROSION AND SEDIMENT CONTROL MEASURES ARE IN PLACE AND PRIOR TO COMMENCEMENT OF WORK.
2. THE EROSION AND SEDIMENT CONTROL MEASURES SHALL BE SITED, DESIGNED AND CONSTRUCTED IN ACCORDANCE WITH THE REQUIREMENTS IN THE CITY OF WOODLAND'S LATEST STANDARD DETAILS AND THE WASHINGTON STATE DEPARTMENT OF ECOLOGY STORMWATER MANUAL FOR WESTERN WASHINGTON, WHERE THE CITY OF WOODLAND GENERAL REQUIREMENTS SHALL TAKE PRECEDENCE.
3. THE DEVELOPER IS RESPONSIBLE FOR MAINTAINING EROSION PREVENTION AND SEDIMENT CONTROL MEASURES DURING AND AFTER INSTALLATION OF ALL UTILITY WORK ASSOCIATED WITH UTILITY TRENCHES.
4. PRIOR TO ANY SITE EXCAVATION, ALL STORM DRAINAGE INLETS SHALL BE PROTECTED DOWN SLOPE FROM ANY DISTURBED OR CONSTRUCTION AREAS PER THE STANDARD DETAILS TO PREVENT SEDIMENT FROM ENTERING THE STORM DRAINAGE SYSTEM PRIOR TO PERMANENT STABILIZATION OF THE DISTURBED AREAS. CLEAN THE FILTER FABRIC AS NECESSARY TO MAINTAIN DRAINAGE. REMOVE FILTER AND CLEAN CATCH BASINS FOLLOWING COMPLETION OF SITEWORK.
5. THE CONTRACTOR SHALL NOT ALLOW SEDIMENT OR DEBRIS TO ENTER NEW OR EXISTING PIPES, CATCH BASINS OR INFILTRATION SYSTEMS.
6. NEWLY CONSTRUCTED OR MODIFIED INLETS AND CATCH BASINS ARE TO BE PROTECTED IMMEDIATELY UPON INSTALLATION.
7. TEMPORARY SEEDING AND MULCHING OF FILL SLOPES AND DIVERSION DIKES SHALL BE COMPLETED WITHIN ONE WEEK AFTER ROUGH GRADING.
8. ALL EXPOSED AND UNWORKED SOILS SHALL BE STABILIZED BY THE APPROPRIATE BEST MANAGEMENT PRACTICES (BMPs). DURING THE PERIOD FROM OCTOBER 1 TO APRIL 30 NO SOIL SHALL BE EXPOSED FOR MORE THAN TWO (2) DAYS. FROM MAY 1 TO SEPTEMBER 30 NO SOIL SHALL BE EXPOSED FOR MORE THAN SEVEN (7) DAYS.
9. MATERIAL STOCKPILES ARE TO BE PROTECTED BY THE FOLLOWING MEANS:
 TEMPORARY: COVER PILES WITH TARPS OR PLASTIC SHEETING WEIGHTED WITH CONCRETE BLOCKS, LUMBER OR TIRES.
 PERMANENT: COVER PILES WITH TARPS OR PLASTIC, OR RESEED. PERIMETER AREAS AROUND PILES ARE TO BE SURROUNDED WITH EROSION CONTROL FILTER FABRIC FENCES UNTIL SOIL SURFACE IS STABILIZED WITH RESEEDING.
10. THE CONTRACTOR SHALL MAINTAIN ON SITE A WRITTEN DAILY LOG OF EROSION CONTROL BMP MAINTENANCE.
11. IF THE CITY INSPECTOR OR ENGINEER(S) HAS EVIDENCE OF POOR CONSTRUCTION PRACTICES OR IMPROPER EROSION PREVENTION BMPs, CITATIONS AND/OR A STOP WORK ORDER SHALL BE ISSUED UNTIL PROPER MEASURES HAVE BEEN TAKEN AND APPROVED BY THE CITY OF WOODLAND. IF THE BMPs APPLIED TO A SITE ARE INSUFFICIENT TO PREVENT SEDIMENT FROM REACHING WATER BODIES, ADJACENT PROPERTIES, OR PUBLIC RIGHT-OF-WAY, THEN THE PUBLIC WORKS DIRECTOR SHALL REQUIRE ADDITIONAL BMPs.

PROTECTION OF ADJACENT PROPERTIES, ROADS AND STREETS

12. PROVIDE A 12-INCH DEEP PAD OF CRUSHED ROCK FOR A DISTANCE OF 100 FEET INTO THE SITE FOR ALL ACCESS POINTS UTILIZED BY CONSTRUCTION EQUIPMENT AND TRUCKS. WIDTH OF THE PAD SHALL BE A MINIMUM OF 20 FEET. ALL TRUCKS LEAVING THE SITE SHALL EGRESS ACROSS THE PAD. ACCUMULATED SOIL SHALL BE PERIODICALLY REMOVED, OR ADDITIONAL ROCK SHALL BE PLACED UPON THE PAD SURFACE. ROCK SHALL BE CLEAN 4 INCH TO 8 INCH QUARRY SPALLS. ALL MATERIALS SPILLED, DROPPED, WASHED OR TRACKED FROM VEHICLES ONTO ROADWAYS OR INTO STORM DRAINS MUST BE REMOVED IMMEDIATELY.
13. PAVEMENT SWEEPING AND SHOVELING IS REQUIRED. WASHING THE PAVEMENT INTO THE STORM SYSTEM IS NOT PERMITTED.
14. AT SITES WITH LESS THAN 1 ACRE OF EXPOSED SOIL, PAD LENGTH MAY BE REDUCED TO 50 FEET. SINGLE FAMILY LOT ENTRANCES MAY HAVE THE PAD LENGTH REDUCED TO 20 FEET. IF CONSTRUCTION OCCURS SIMULTANEOUSLY ON ADJACENT LOTS WITH THE SAME OWNER DURING CONSTRUCTION, ONE LOT ENTRANCE MAY BE USED FOR THE ADJACENT LOTS.
15. INSTALL SEDIMENT FENCE IN ACCORDANCE WITH THIS DETAIL SHEET PRIOR TO BUILDING CONSTRUCTION AND/OR EXCAVATION TO PREVENT SILT INTRUSION UPON ADJACENT LOTS. IF CONSTRUCTION OCCURS SIMULTANEOUSLY ON ADJACENT LOTS AND THE LOTS HAVE THE SAME OWNER DURING CONSTRUCTION, THE SILT FENCE ALONG THE COMMON LOT LINE MAY BE ELIMINATED.
16. CONSTRUCTION ROADS AND PARKING AREAS SHALL BE STABILIZED WHEREVER THEY ARE CONSTRUCTED, WHETHER PERMANENT OR TEMPORARY, FOR THE USE OF CONSTRUCTION TRAFFIC.

MAINTENANCE OF SEDIMENT CONTROL BMPs

17. MAINTAIN AND REMOVE ALL SEDIMENT CONTROLS AS SPECIFIED IN THE STANDARD DETAILS. THE CONTRACTOR SHALL REMOVE ALL ACCUMULATED SEDIMENT FROM THE CATCH BASINS, DRYWELLS, UTILITY TRENCHES AND STORM PIPES PRIOR TO ACCEPTANCE BY THE CITY.
18. SEDIMENT CONTROL BMPs SHALL BE INSPECTED WEEKLY AND AFTER ANY STORM EVENT PRODUCING RUNOFF. THE INSPECTION FREQUENCY FOR STABILIZED, INACTIVE SITES SHALL BE ONCE EVERY TWO WEEKS OR MORE FREQUENTLY AS DETERMINED BY THE LOCAL PERMITTING AUTHORITY BASED ON THE LEVEL OF SOIL STABILITY AND POTENTIAL FOR ADVERSE ENVIRONMENTAL IMPACTS.
19. ALL TEMPORARY EROSION PREVENTION AND SEDIMENT CONTROL MEASURES SHALL BE REMOVED WITHIN 30 DAYS AFTER SITE STABILIZATION IS ACHIEVED OR AFTER TEMPORARY BMPs ARE NO LONGER NEEDED. TRAPPED SEDIMENT SHALL BE REMOVED OR STABILIZED ON SITE. DISTURBED SOIL AREAS RESULTING FROM REMOVAL SHALL BE PERMANENTLY STABILIZED.

DUST CONTROL

20. IN AREAS SUBJECT TO SURFACE AND AIR MOVEMENT OF DUST ONE OR MORE OF THE FOLLOWING PREVENTATIVE MEASURES SHALL BE TAKEN FOR DUST CONTROL:
 - A. MINIMIZE THE PERIOD OF SOIL EXPOSURE THROUGH THE USE OF TEMPORARY GROUND COVER AND OTHER TEMPORARY STABILIZATION PRACTICES.
 - B. SPRINKLE THE SITE WITH WATER UNTIL THE SURFACE IS WET.
 - C. SPRAY EXPOSED SOIL AREAS WITH A DUST PALLIATIVE. NOTE: USE OF PETROLEUM PRODUCTS OR POTENTIALLY HAZARDOUS MATERIALS ARE PROHIBITED

TEMPORARY SEEDING

21. EXPOSED SURFACES THAT WILL NOT BE BROUGHT TO FINAL GRADE OR GIVEN A PERMANENT COVER TREATMENT WITHIN 30 DAYS OF THE EXPOSURE SHALL HAVE SEED MIX AND MULCH PLACED TO STABILIZE THE SOIL AND REDUCE EROSION SEDIMENTATION. SEEDED AREAS SHALL BE CHECKED REGULARLY TO ASSURE A GOOD STAND OF GRASS IS BEING MAINTAINED. AREAS THAT FAIL TO ESTABLISH VEGETATION COVER ADEQUATE TO PREVENT EROSION WILL BE RESEEDED AS SOON AS SUCH AREAS ARE IDENTIFIED.
22. APPLY AN APPROVED TEMPORARY SEEDING MIXTURE TO THE PREPARED SEED BED AT A RATE OF 120 LBS/ACRE. NOTE: "HYDROSEEDING" APPLICATIONS WITH APPROVED SEED-MULCH-FERTILIZER MIXTURES MAY ALSO BE USED.

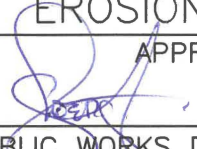
	EROSION PREVENTION AND SEDIMENT CONTROL				E-03
	APPROVED  PUBLIC WORKS DIRECTOR	REVISIONS	DATE	DRAWN	
	2/14/08 DATE				

DO NOT NAIL OR STAPLE WIRE TO TREES

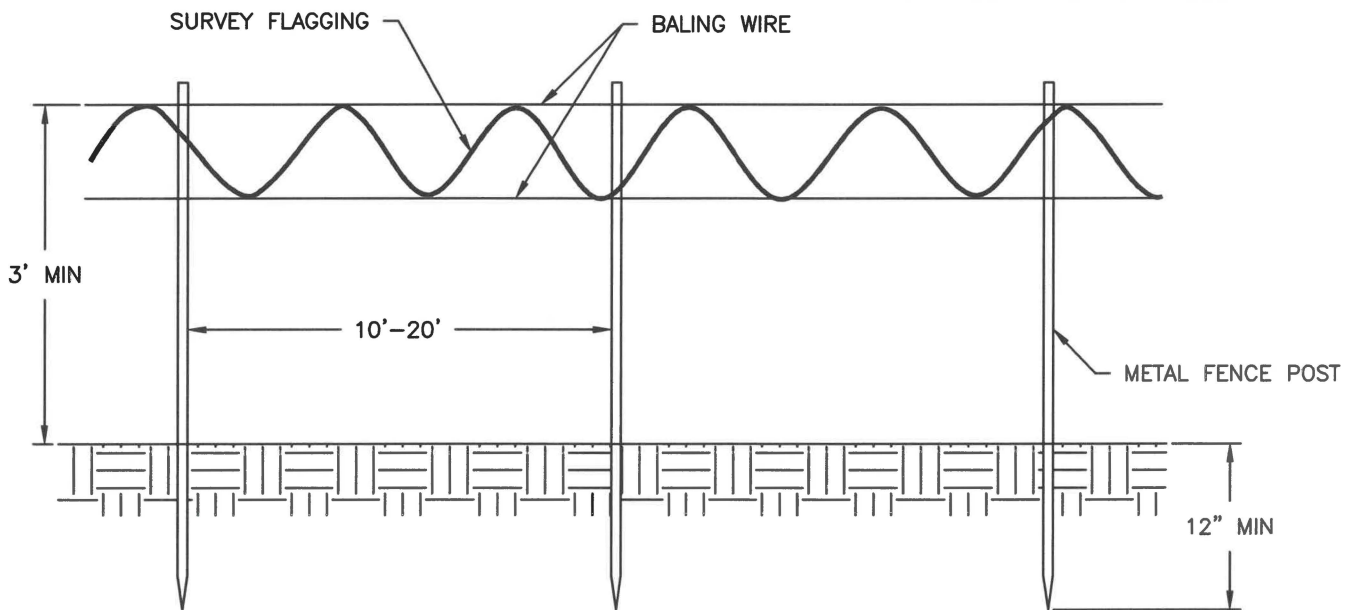

STAKE AND WIRE FENCE



APPROVED *[Signature]*
 PUBLIC WORKS DIRECTOR

DATE *2/14/02*

REVISIONS	DATE	DRAWN	DESIGNED

E-04

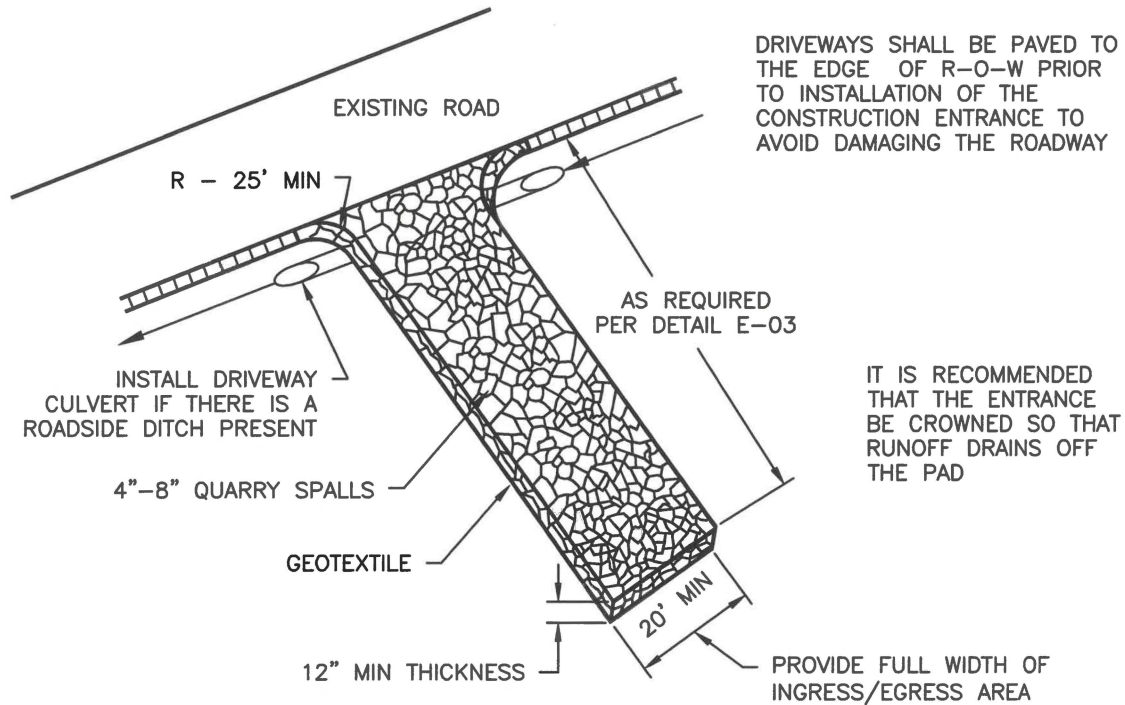

NOTES:

1. IF THE ENTRANCE SITS ON A SLOPE, PLACE A FILTER FABRIC FENCE DOWN GRADIENT.
2. TOP DRESS THE PAD WITH CLEAN 3" MINUS ROCK WHEN THE CONSTRUCTION ENTRANCE BECOMES CLOGGED WITH SEDIMENTS.
3. ANY SEDIMENT CARRIED FROM THE SITE ONTO THE STREET SHALL BE CLEANED UP IMMEDIATELY.
4. IF EQUIPMENT TRAVELS EXTENSIVELY ON UNSTABILIZED ROADS ON THE SITE, A TIRE AND VEHICLE UNDERCARRIAGE WASH NEAR THE ENTRANCE WILL BE NEEDED. PERFORM WASHING ON CRUSHED ROCK. WASH WATER WILL REQUIRE TREATMENT IN A SEDIMENT POND OR TRAP.

STABILIZED CONSTRUCTION ENTRANCE



APPROVED

 PUBLIC WORKS DIRECTOR

DATE
 2/14/22

REVISIONS	DATE	DRAWN	DESIGNED

E-05

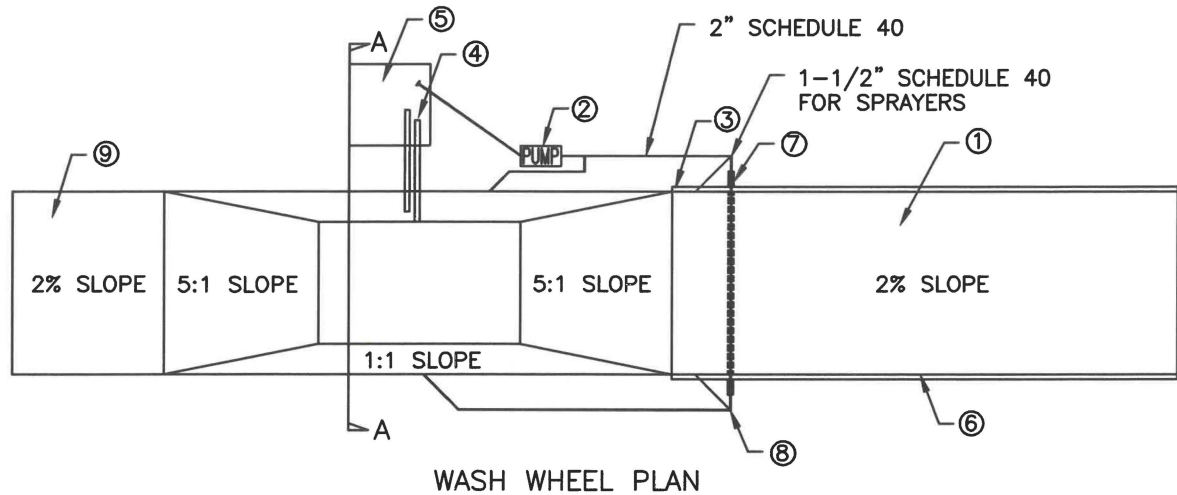

WASH WHEEL PLAN

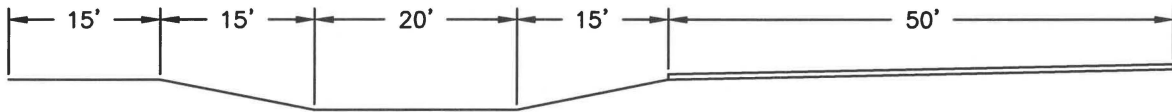

ELEVATION VIEW

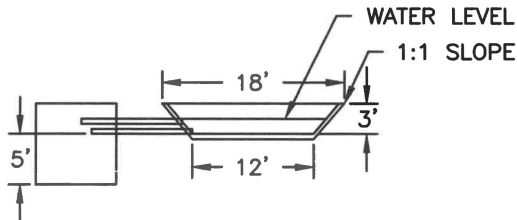

SECTION A-A

- ① ASPHALT CONSTRUCTION ENTRANCE 6" ASPHALT TREATED BASE (ATB).
- ② 3" TRASH PUMP WITH FLOATS ON THE SUCTION HOSE.
- ③ MIDPOINT SPRAY NOZZLES, IF NEEDED.
- ④ 6" SEWER PIPE WITH BUTTERFLY VALVES, BOTTOM ONE IS A DRAIN. LOCATE TOP PIPE'S INVERT 1' ABOVE BOTTOM OF WHEEL WASH.
- ⑤ 8' X 8' SUMP WITH 5' OF CATCH, BUILD SO CAN BE CLEANED WITH TRACKHOE.
- ⑥ 6" ASPHALT CURB ON THE LOW ROAD SIDE TO DIRECT WATER BACK TO POND.
- ⑦ 6" SLEEVE UNDER ROAD.
- ⑧ BALL VALVES.
- ⑨ 15' ATB APRON TO PROTECT GROUND FROM SPLASHING WATER.

WHEEL WASH



APPROVED

 PUBLIC WORKS DIRECTOR
 DATE 2/14/22

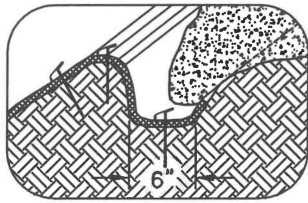
REVISIONS	DATE	DRAWN	DESIGNED

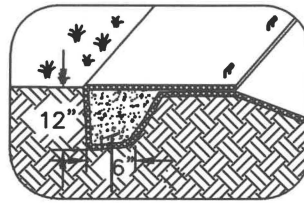

LONGITUDINAL ANCHOR TRENCH



TERMINAL SLOPE & CHANNEL ANCHOR TRENCH

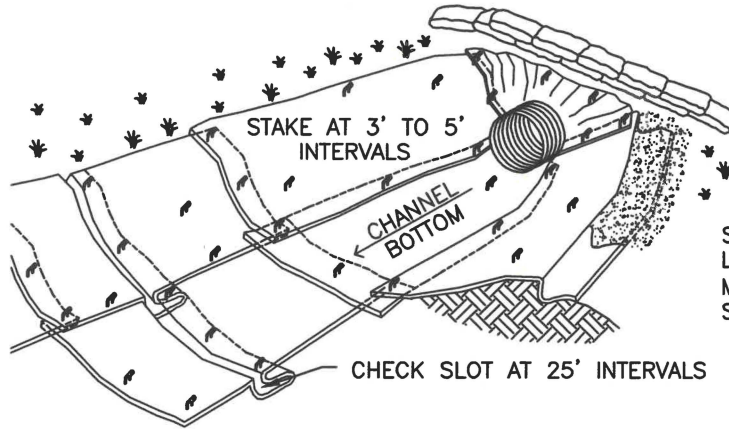

ISOMETRIC VIEW

STAKING OF STAPLING LAYOUT PER MANUFACTURER'S SPECIFICATIONS

CHECK SLOTS TO BE CONSTRUCTED PER MANUFACTURER'S SPECIFICATIONS

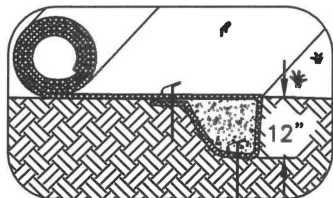

INITIAL CHANNEL ANCHOR TRENCH

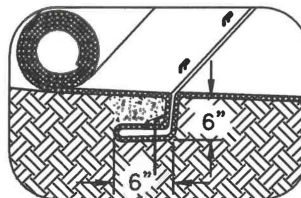

INTERMITTENT CHECK SLOT

CHANNEL INSTALLATION

SLOPE SURFACE SHALL BE SMOOTH BEFORE PLACEMENT FOR PROPER SOIL CONTACT

STAPLING PATTERN AS PER MANUFACTURER'S SPECIFICATIONS

IF THERE IS A BERM AT THE TOP OF SLOPE, ANCHOR UPSLOPE OF THE BEAM

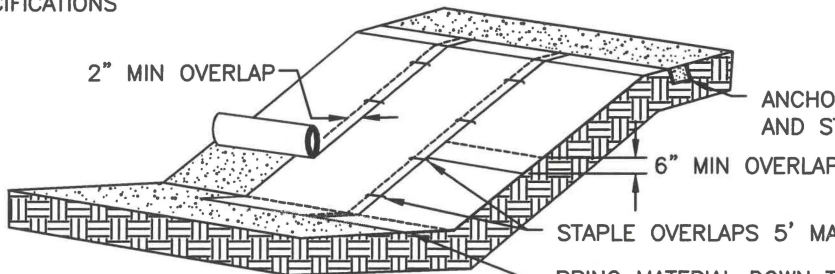

ANCHOR IN 6" X 6" MIN TRENCH AND STAPLE AT 12" INTERVALS

STAPLE OVERLAPS 5' MAX SPACINGS

DO NOT STRETCH BLANKETS/MATTINGS TIGHT, ALLOW THE ROLLS TO MOLD TO ANY IRREGULARITIES

FOR SLOPES LESS THAN 3H:1V, ROLLS MAY BE PLACED IN HORIZONTAL STRIPS

BRING MATERIAL DOWN TO A LEVEL AREA, TURN THE END UNDER 4" AND STAPLE AT 12" INTERVALS

LIME, FERTILIZE, AND SEED BEFORE INSTALLATION; PLANTING OF SHRUBS, TREES, ETC. SHOULD OCCUR AFTER INSTALLATION

SLOPE INSTALLATION

NETS AND BLANKETS

APPROVED

[Signature]
PUBLIC WORKS DIRECTOR

2/14/08

DATE

REVISIONS

DATE

DRAWN

DESIGNED

E-07



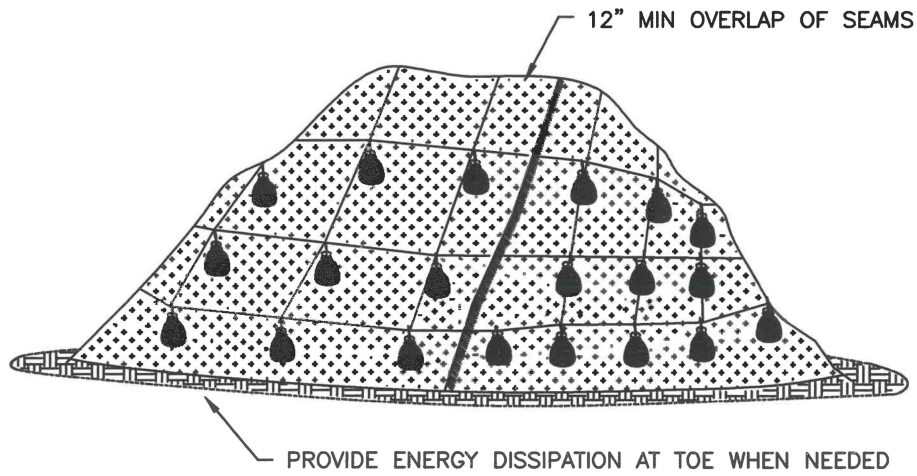

PLASTIC SHEETING

NOTES:

1. PLASTIC SHEETING IS USED TO PROVIDE IMMEDIATE PROTECTION TO SLOPES AND STOCKPILES.
2. DO NOT USE PLASTIC COVERING UPSLOPE OF AREAS SUCH AS STEEP AND/OR UNSTABLE SLOPES THAT MIGHT BE ADVERSELY AFFECTED BY CONCENTRATED RUNOFF.
3. WHEN POSSIBLE, INSTALL AN INTERCEPTOR DIKE AT THE TOP OF THE PLASTIC TO DIVERT FLOWS AWAY FROM THE PLASTIC.
4. TOE-IN THE TOP OF THE SHEETING IN A 6"x6" TRENCH BACKFILLED WITH COMPACTED NATIVE MATERIAL.
5. INSTALL A GRAVEL BERM, RIPRAP, OR OTHER SUITABLE PROTECTION AT THE TOP OF THE SLOPE IN ORDER TO DISSIPATE RUNOFF VELOCITY.
6. ANCHOR THE PLASTIC USING SANDBAGS OR OTHER SUITABLE TETHERED ANCHOR SYSTEM SPACED ON A 10' GRID SPACING IN ALL DIRECTIONS.
7. OVERLAP SEAMS 1-2', TAPE, ROLL AND STAKE THE SEAMS AND THEN WEIGH DOWN THE ENTIRE LENGTH.
8. PROVIDE ENERGY DISSIPATION AT TOE WHEN NEEDED.
9. REPLACE TORN SHEETS AND REPAIR OPEN SEAMS; COMPLETELY REMOVE AND REPLACE PLASTIC WHEN IT BEGINS TO DETERIORATE.

PLASTIC COVERING



APPROVED *[Signature]*
 PUBLIC WORKS DIRECTOR
 DATE 2/14/22

REVISIONS	DATE	DRAWN	DESIGNED

E-08

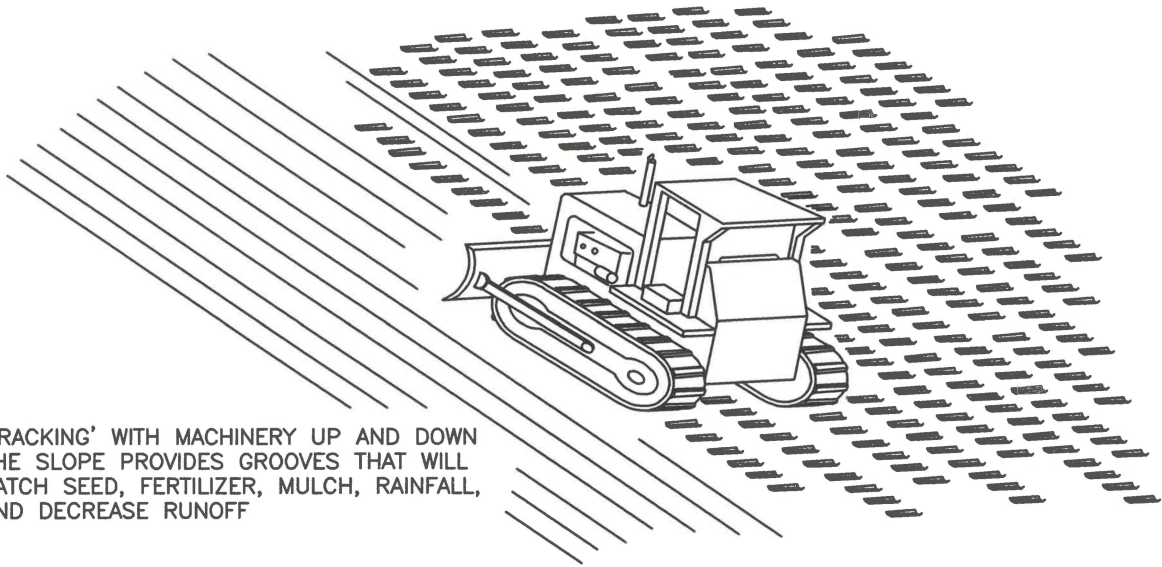

'TRACKING' WITH MACHINERY UP AND DOWN THE SLOPE PROVIDES GROOVES THAT WILL CATCH SEED, FERTILIZER, MULCH, RAINFALL, AND DECREASE RUNOFF

TRACKING

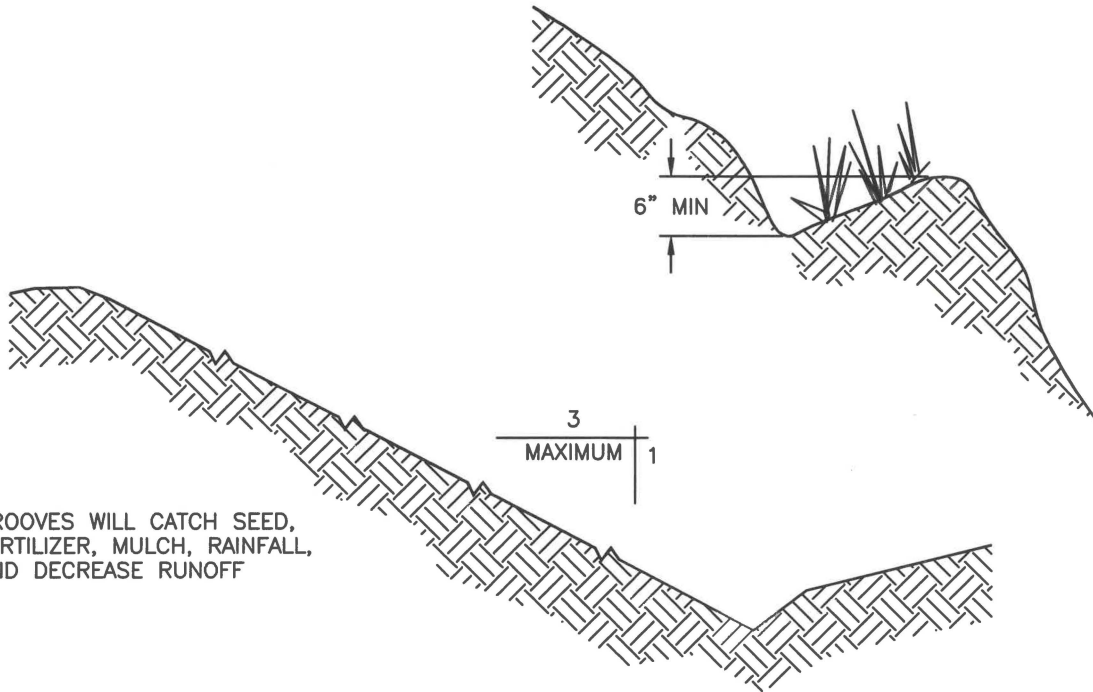

GROOVES WILL CATCH SEED, FERTILIZER, MULCH, RAINFALL, AND DECREASE RUNOFF

CONTOUR FURROWS

SURFACE ROUGHENING

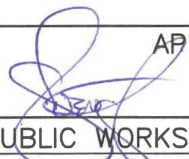

APPROVED

 PUBLIC WORKS DIRECTOR
 DATE 2/14/22

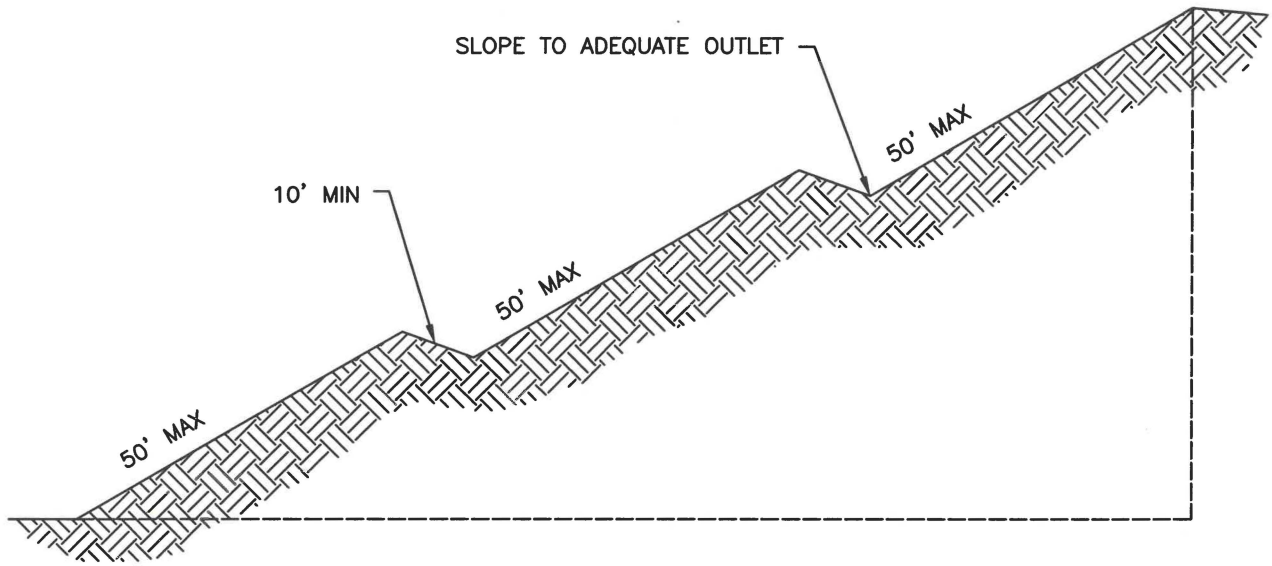
REVISIONS	DATE	DRAWN	DESIGNED



NOTES:

1. ALL GRADIENT TERRACES SHOULD HAVE ADEQUATE OUTLETS. SUCH AN OUTLET MAY BE A GRASSED WATERWAY, VEGETATED AREA, OR TILE OUTLET.
2. IN ALL CASES THE OUTLET MUST CONVEY RUNOFF FROM THE TERRACE OR TERRACE SYSTEM TO A POINT WHERE THE OUTFLOW WILL NOT CAUSE DAMAGE. VEGETATIVE COVER SHOULD BE USED IN THE OUTLET CHANNEL.

GRADIENT TERRACES



APPROVED

 PUBLIC WORKS DIRECTOR
 DATE 2/14/22

REVISIONS	DATE	DRAWN	DESIGNED

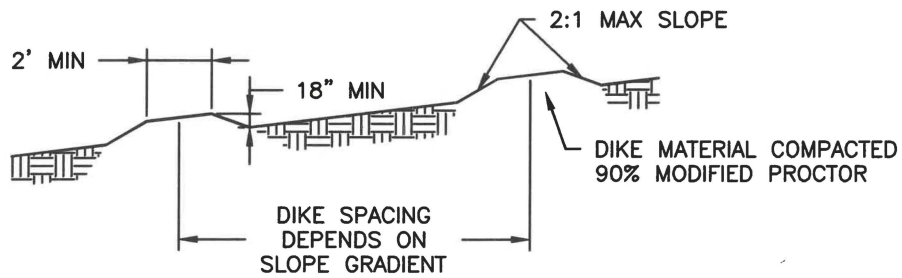
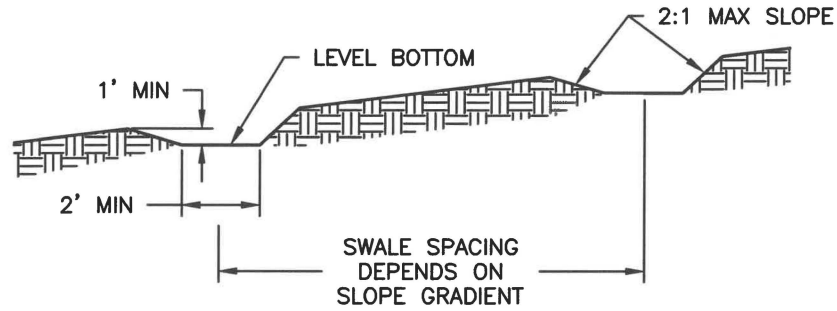

NOTES:

1. MAXIMUM SLOPE OF FLOW PATH SHALL BE EQUAL TO OR LESS THAN 5%.
2. SIDE SLOPE OF INTERCEPTOR SWALES SHALL BE NO GREATER THAN 2:1.
3. MAXIMUM LENGTH BETWEEN SWALES:

SLOPE	<5%	5-10%	10-40%
DISTANCE	300 FT	200 FT	100 FT

INTERCEPTOR DIKE AND SWALE



APPROVED

PUBLIC WORKS DIRECTOR

DATE 2/14/22

REVISIONS	DATE	DRAWN	DESIGNED

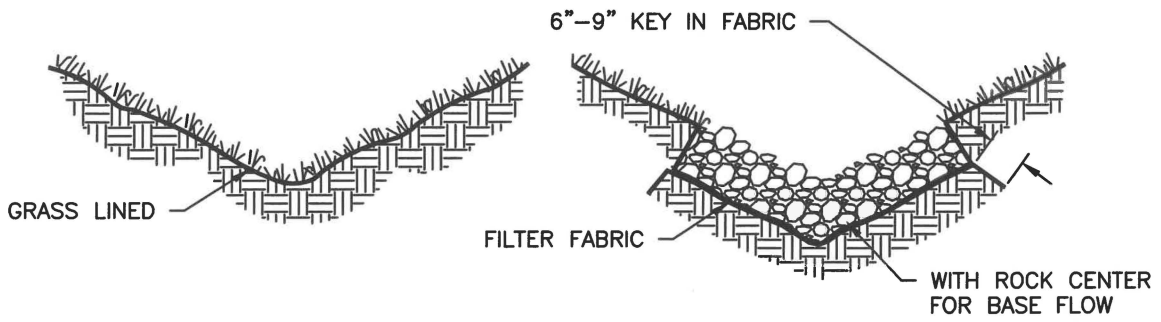

TYPICAL V-SHAPED CHANNEL CROSS-SECTION

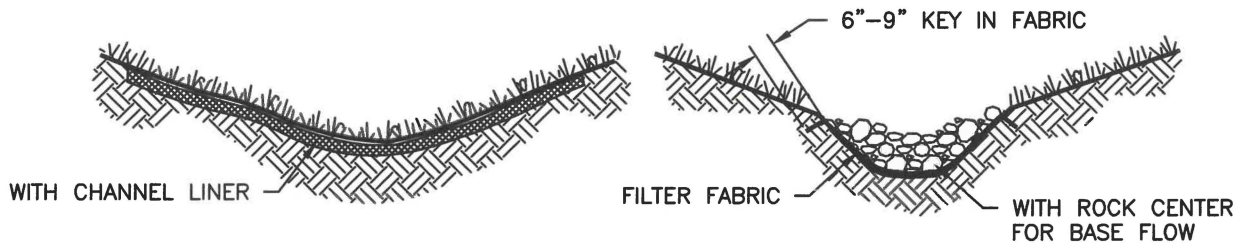

TYPICAL PARABOLIC CHANNEL CROSS-SECTION

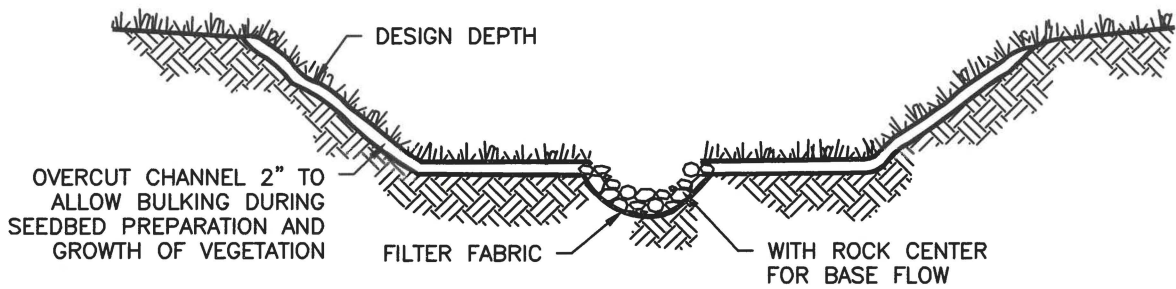

TYPICAL TRAPEZOIDAL CHANNEL CROSS-SECTION

GRASS-LINED CHANNELS



APPROVED *[Signature]*
 PUBLIC WORKS DIRECTOR
 DATE 2/14/22

REVISIONS	DATE	DRAWN	DESIGNED

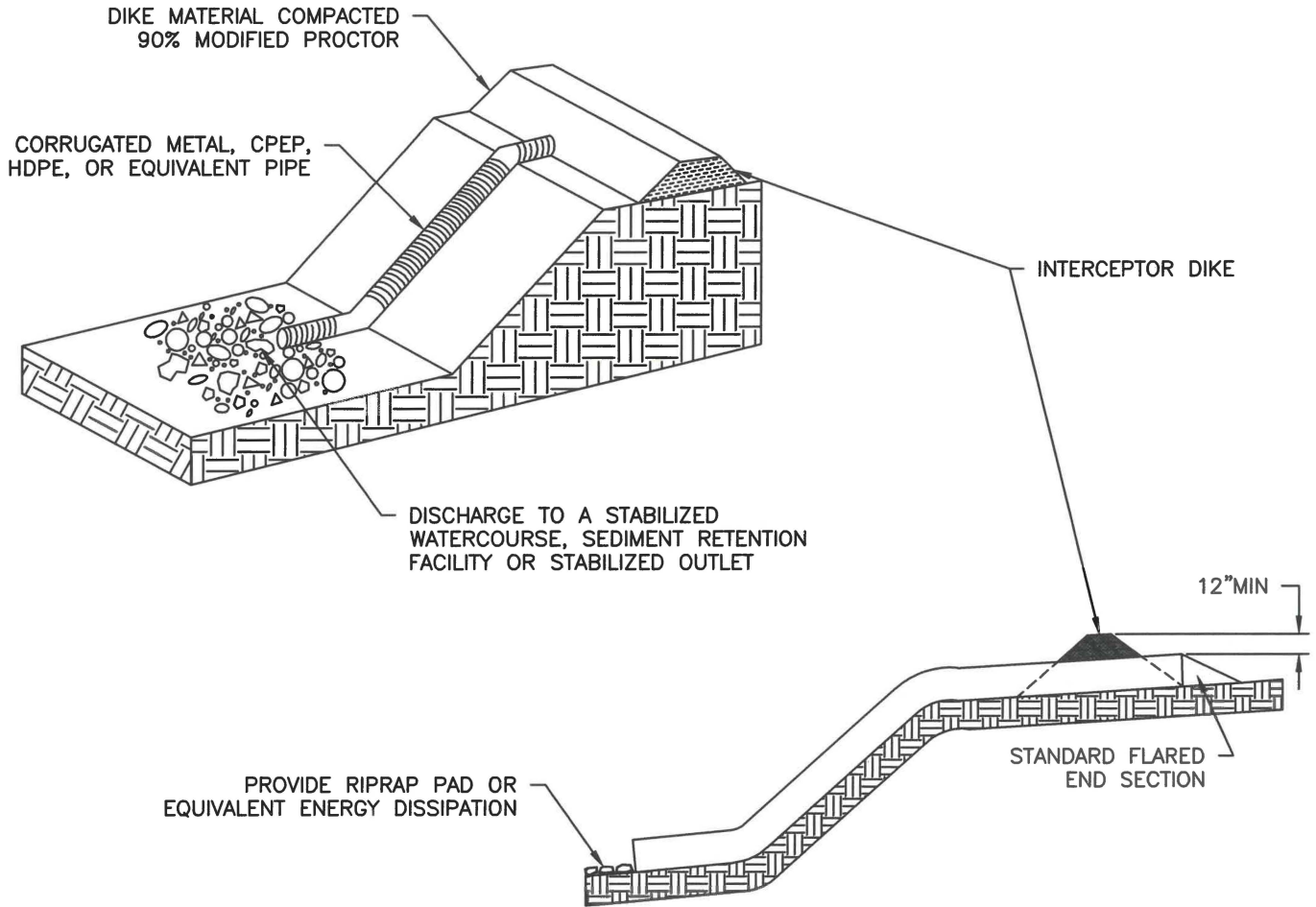

NOTE:

1. INLET AND ALL PIPE SECTIONS MUST BE SECURELY FASTENED TOGETHER WITH GASKETED WATERTIGHT FITTINGS.

PIPE SLOPE DRAINS



APPROVED

 PUBLIC WORKS DIRECTOR

2/14/22
 DATE

REVISIONS	DATE	DRAWN	DESIGNED

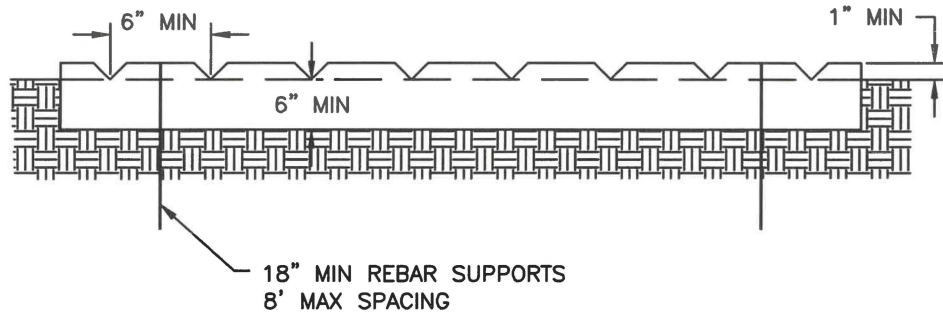
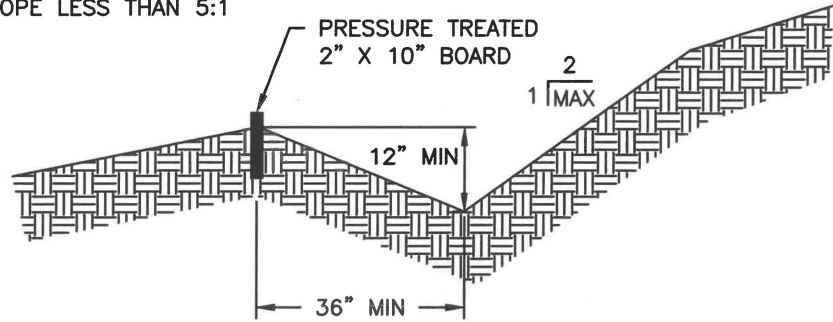
DENSELY VEGETATED FOR
A MIN OF 100' AND
SLOPE LESS THAN 5:1



NOTES:

1. SPREADER MUST BE LEVEL END TO END.
2. TREATED 2" X 10" WOOD BEAMS MAY BE ABUTTED END TO END FOR MAX SPREADER LENGTH OF 50'.
3. ALTERNATIVELY, 6" DIAMETER CMP MAY BE USED AS A SPREADER. THE PIPE SHALL BE BURIED SO THAT ONLY 1" EXTENDS ABOVE GROUND.

LEVEL SPREADER



APPROVED
[Signature]
PUBLIC WORKS DIRECTOR

2/14/08
DATE

REVISIONS	DATE	DRAWN	DESIGNED

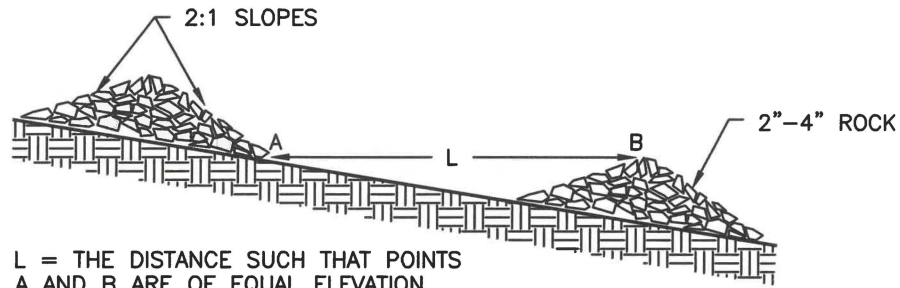
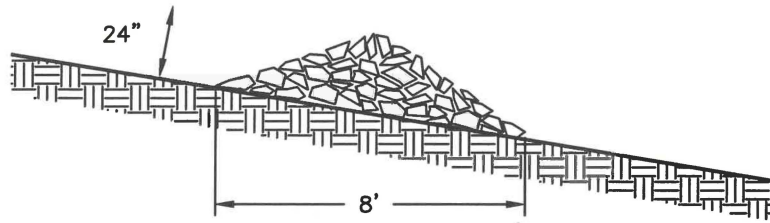

L = THE DISTANCE SUCH THAT POINTS A AND B ARE OF EQUAL ELEVATION

SPACING BETWEEN CHECK DAMS

NOTES:

1. CHECK DAMS ARE CONSTRUCTED ACROSS A SWALE OR DITCH TO REDUCE VELOCITIES OF CONCENTRATED FLOWS, THEREBY REDUCING EROSION AND ALLOWING A SIGNIFICANT AMOUNT OF SUSPENDED SEDIMENT TO SETTLE OUT.
2. CHECK DAMS SHALL BE USED IN TEMPORARY OR PERMANENT CHANNELS THAT DRAIN 10-ACRES OR LESS, ARE NOT YET VEGETATED, AND WHEN INSTALLING CHANNEL LINING IS NOT FEASIBLE.
3. USE TYPICAL ROCK SIZE OF 2"-4". PLACE ROCK BY HAND OR BY MECHANICAL MEANS RATHER THAN DUMPING THE ROCK. BRIDGE ENTIRE DITCH OR SWALE WIDTH AND ENSURE THE CENTER OF THE DAM IS 6" LOWER THAN THE OUTER ENDS. FOR HIGHER VELOCITY FLOWS: ±5 FPS USE 6"-12" RIPRAP, AND HAND PLACE LARGER ROCK ON UPSTREAM SIDE OF DAM.
4. REMOVE CHECK DAMS FROM GRASS-LINED DITCHES AND SWALES ONCE THE GRASS IS ESTABLISHED. SEED, MULCH, OR MAT THE AREA WHERE THE CHECK DAMS WERE IMMEDIATELY FOLLOWING REMOVAL.
5. INSPECT ONCE PER WEEK ON ACTIVE SITES, ONCE EVERY TWO WEEKS ON INACTIVE SITES, AND WITHIN 24-HOURS FOLLOWING A 0.5" RAIN EVENT. REMOVE SEDIMENT ONCE IT REACHES ONE-THIRD THE DEPTH OF THE ROCK WEIR. REPLACE ROCK WEIR WHEN FILTERING CAPACITY IS REDUCED BY ONE-HALF.

6. SPACING TABLE FOR CHECK DAMS:

DITCH GRADE	MINIMUM WEIR DEPTH		
	6 INCH	12 INCH	18 INCH
6%	**	L=16 ft O.C.	L=26 ft O.C.
5%	**	L= 20 ft	L= 30 ft
4%	**	L= 26 ft	L= 40 ft
3%	15 ft	L= 33 ft	L= 50 ft
2%	25 ft	L= 50 ft	L= 80 ft

**NOT ALLOWED

CHECK DAM



APPROVED

 PUBLIC WORKS DIRECTOR
 DATE 2/14/22

REVISIONS	DATE	DRAWN	DESIGNED

BIO-FILTER BAGS OR STRAW WATTLES MAY BE USED SHORT TERM WITH UTILITY WORK AND WITH PHASING OF DEVELOPMENT

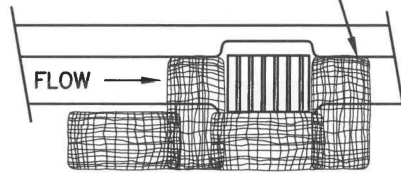

CATCH BASIN

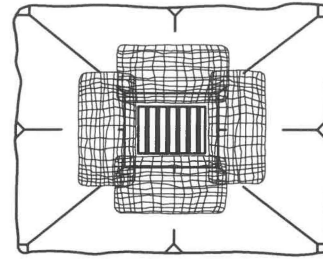

AREA DRAIN

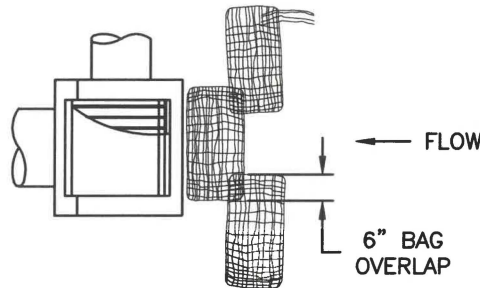

PLAN VIEW

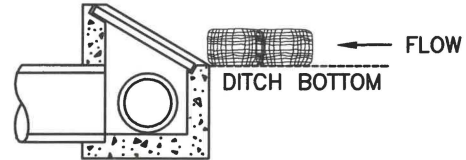

DITCH INLET

NOTES:

1. ADDITIONAL MEASURES MUST BE CONSIDERED DEPENDING ON SOIL TYPE.
2. BIO-FILTER BAGS SHOULD BE STAKED WHERE APPLICABLE USING (2) 1" x 2" WOODEN STAKES OR APPROVED EQUAL PER BAG.
3. STRAW WATTLES MUST BE STABILIZED BY ATTACHING WIRE CLIPS TO THE CATCH BASIN PER MANUFACTURER SPECIFICATIONS.
4. INLET PROTECTION MUST BE REGULARLY INSPECTED BY THE EROSION CONTROL INDIVIDUAL TO INSURE PROPER PLACEMENT/FUNCTION AND MAINTENANCE.

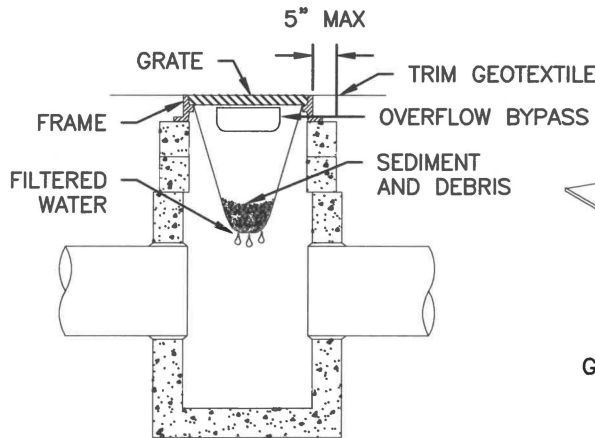

CROSS SECTION

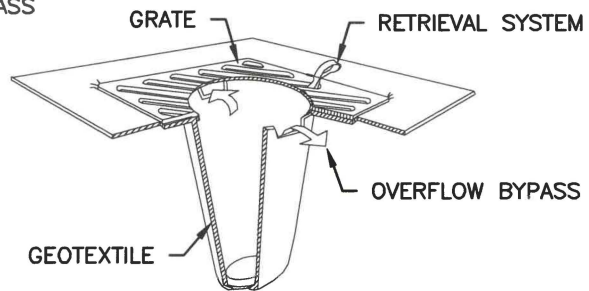

ISOMETRIC VIEW

NOTES:

1. SIZE THE BELOW GRATE INLET DEVICE (BGID) FOR THE STORM WATER STRUCTURE IT WILL SERVICE.
2. THE REMOVAL SYSTEM MUST ALLOW REMOVAL OF THE BGID WITHOUT SPILLING THE COLLECTED MATERIAL.
3. THE BGID SHALL HAVE A BUILT-IN HIGH-FLOW RELIEF SYSTEM (OVERFLOW BYPASS).
4. THE CONTRACTOR SHALL INSPECT THE BAG AFTER EACH STORM EVENT AND AT REGULAR INTERVALS.
5. THE FILTER BAG SHALL BE CLEANED OR REPLACED WHEN THE BAG BECOMES HALF FULL.

INLET PROTECTION (1 OF 2)



APPROVED *[Signature]*
PUBLIC WORKS DIRECTOR DATE *[Signature]*

REVISIONS	DATE	DRAWN	DESIGNED

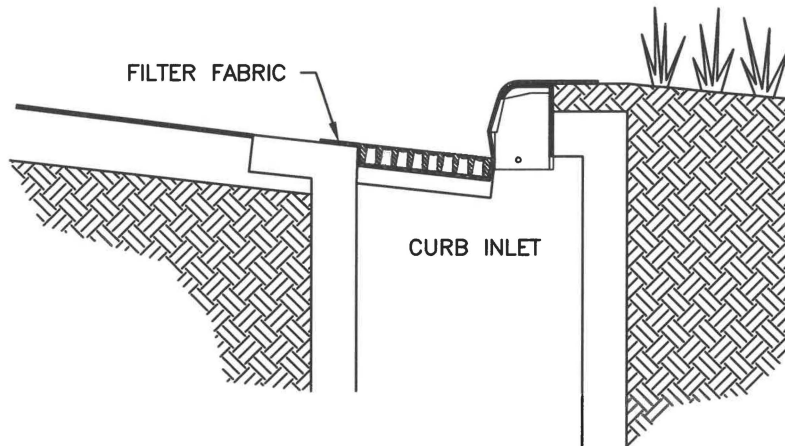
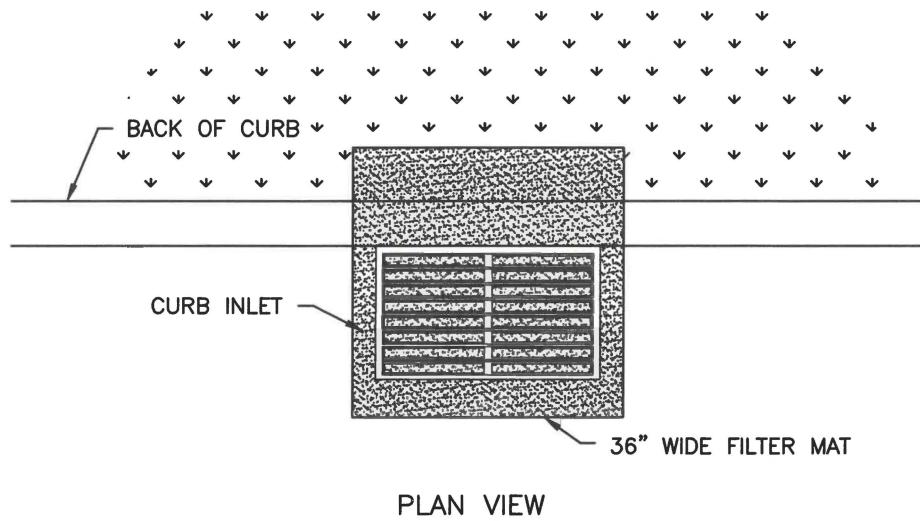

NOTES:

1. USE FILTER MAT SEDIMENT BARRIER WHEN CURB INLET IS LOCATED IN GENTLY SLOPING STREET, WITH MINIMAL NEED, WHERE WATER CAN FILTER AND ALLOW SEDIMENT TO SEPARATE FROM RUNOFF.
2. BARRIER SHALL ALLOW FOR OVERFLOW FROM SEVERE STORM EVENT.
3. INSPECT BARRIERS AND REMOVE SEDIMENT AFTER EACH STORM EVENT. SEDIMENT MUST BE REMOVED FROM THE TRAVELED WAY IMMEDIATELY.

INLET PROTECTION (2 OF 2)



APPROVED *[Signature]*
 PUBLIC WORKS DIRECTOR DATE *2/14/22*

REVISIONS	DATE	DRAWN	DESIGNED

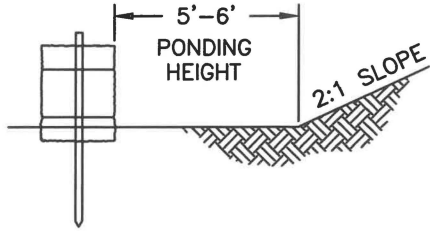

EMBED STRAW BALE
4" MIN INTO SOIL

SECTION A-A

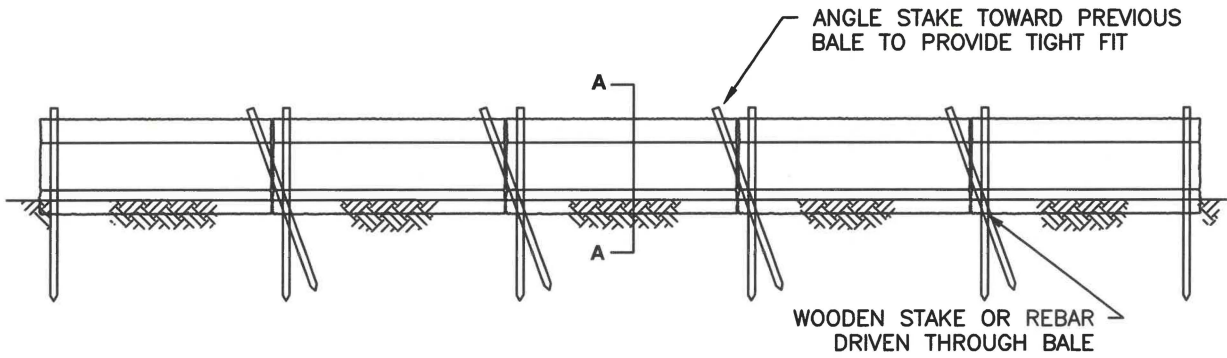

SECTION B-B

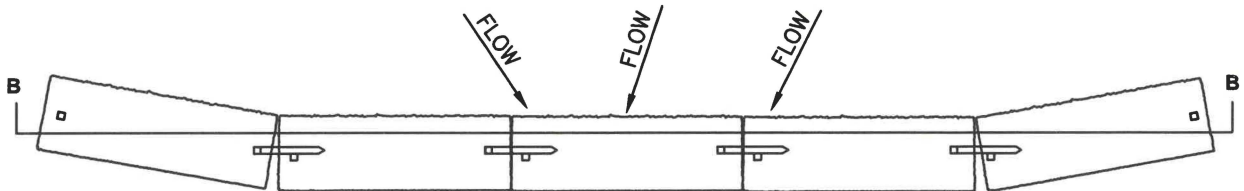

PLAN

NOTES:

1. THE STRAW BALES SHALL BE PLACED ON SLOPE CONTOUR.
2. BALES TO BE PLACED IN A ROW WITH THE ENDS TIGHTLY ABUTTING.
3. KEY IN BALES TO PREVENT EROSION OR FLOW UNDER BALES.

STRAW BALE BARRIER



APPROVED
[Signature]
PUBLIC WORKS DIRECTOR

DATE
1/14/22

REVISIONS	DATE	DRAWN	DESIGNED

IF REQUIRED, DRAPE BURLAP, JUTE MATTING, OR EQUIVALENT FABRIC OVER BRUSH AND SECURE IN 4" X 4" MIN TRENCH WITH COMPACTED BACKFILL

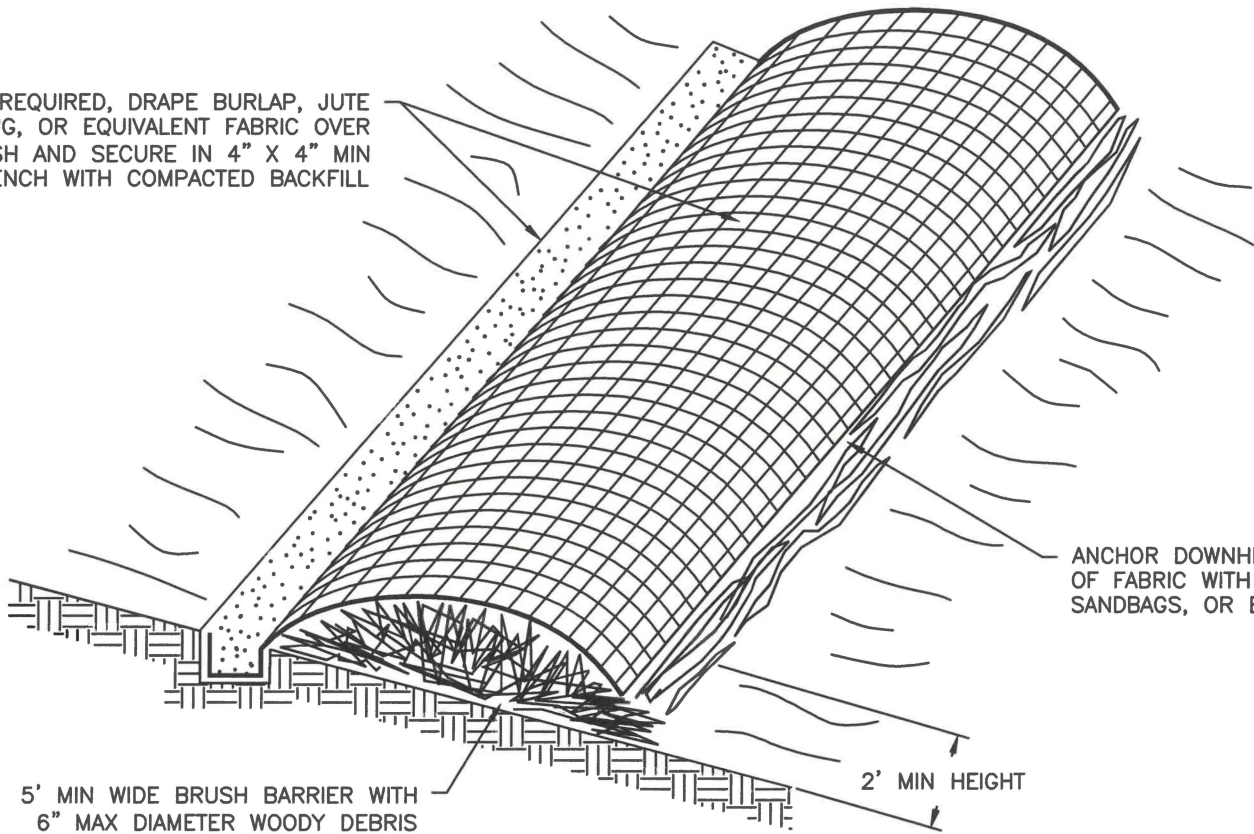

ANCHOR DOWNHILL EDGE OF FABRIC WITH STAKES, SANDBAGS, OR EQUIVALENT

5' MIN WIDE BRUSH BARRIER WITH 6" MAX DIAMETER WOODY DEBRIS

2' MIN HEIGHT

ALTERNATIVELY, TOPSOIL STRIPPINGS MAY BE USED TO FORM BARRIER

BRUSH BARRIER

APPROVED

REVISIONS

DATE

DRAWN

DESIGNED



PUBLIC WORKS DIRECTOR

DATE

E-19

[Handwritten signature]
2/14/02

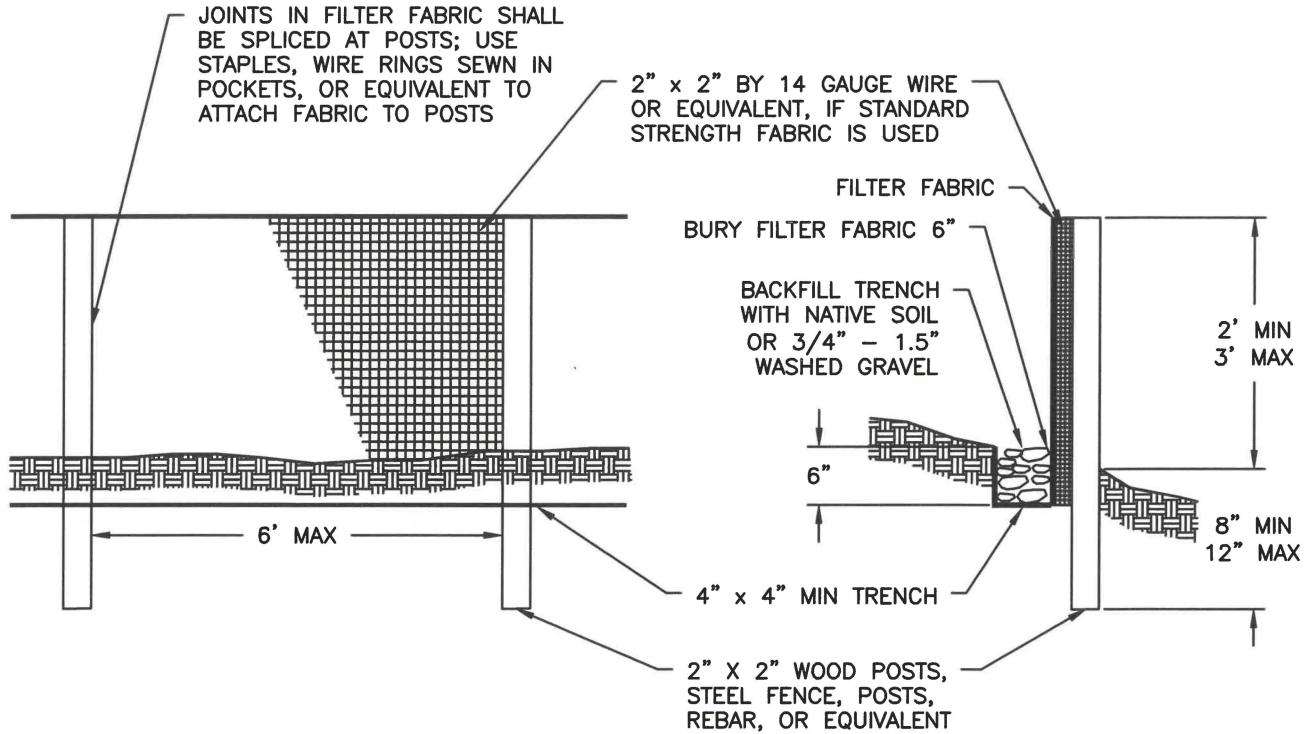

FRONT VIEW

SIDE VIEW

NOTES:

1. FILTER FABRIC FENCES SHALL BE INSTALLED ALONG CONTOUR WHENEVER POSSIBLE.
2. POST SPACING MAY BE INCREASED TO 8' IF WIRE BACKING IS USED.

MAINTENANCE STANDARDS:

1. SILT FENCES AND FILTER BARRIERS SHALL BE INSPECTED IMMEDIATELY AFTER EACH RAINFALL AND AT LEAST DAILY DURING PROLONGED RAINFALL. ANY REQUIRED REPAIRS SHALL BE MADE IMMEDIATELY.
2. IF CONCENTRATED FLOWS ARE EVIDENT UPHILL OF THE FENCE, THEY MUST BE INTERCEPTED AND CONVEYED TO A SEDIMENT POND.
3. IT IS IMPORTANT TO CHECK THE UPHILL SIDE OF THE FENCE FOR SIGNS OF THE FENCE CLOGGING AND ACTING AS A BARRIER TO FLOW AND THEN CAUSING CHANNELIZATION OF FLOWS PARALLEL TO THE FENCE. IF THIS OCCURS, REPLACE THE FENCE OR REMOVE THE TRAPPED SEDIMENT.
4. SEDIMENT DEPOSITS SHALL EITHER BE REMOVED WHEN THE DEPOSIT REACHES APPROXIMATELY ONE-THIRD THE HEIGHT OF THE SILT FENCE, OR A SECOND SILT FENCE SHALL BE INSTALLED.
5. IF THE FILTER FABRIC (GEOTEXTILE) HAS DETERIORATED DUE TO ULTRAVIOLET BREAKDOWN, IT SHALL BE REPLACED.

SILT FENCE



APPROVED *[Signature]*
 PUBLIC WORKS DIRECTOR DATE *2/14/22*

REVISIONS	DATE	DRAWN	DESIGNED

STRAW ROLLS MUST BE PLACED ALONG SLOPE CONTOURS

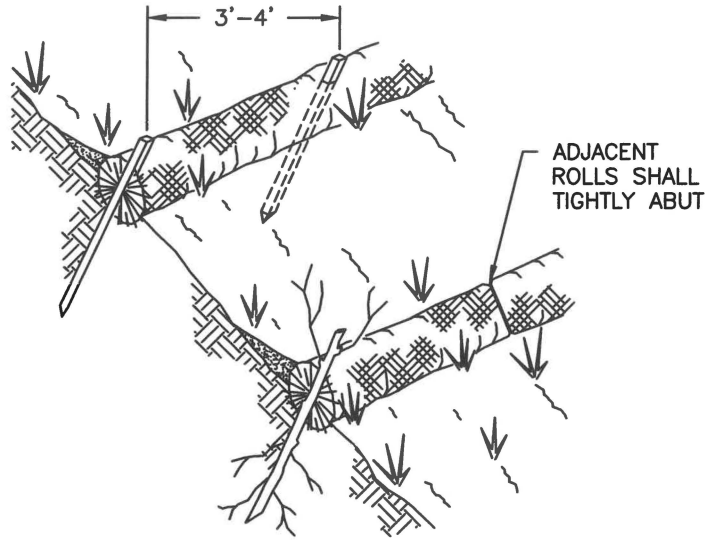

SPACING DEPENDS ON SOIL TYPE AND SLOPE STEEPNESS

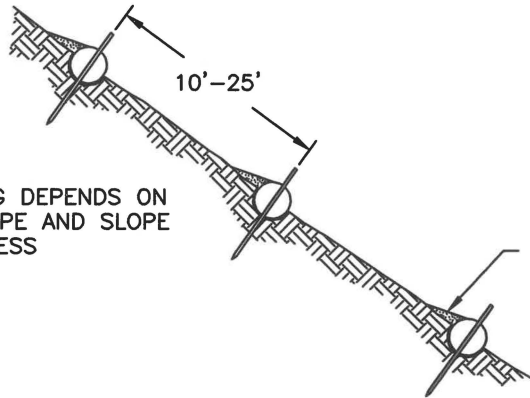

SEDIMENT, ORGANIC MATTER, AND NATIVE SEEDS ARE CAPTURED BEHIND THE ROLLS

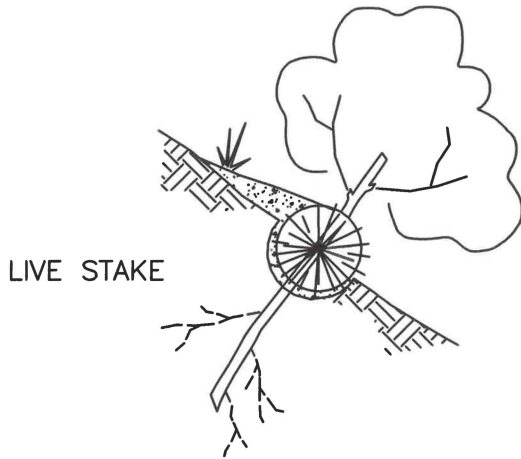

LIVE STAKE

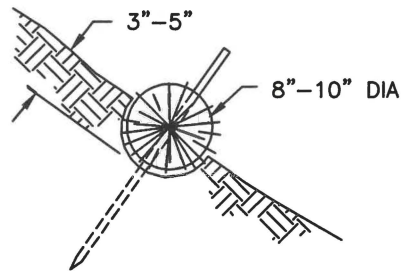

1" x 1" STAKE

NOTES:

1. STRAW ROLL INSTALLATION REQUIRES THE PLACEMENT AND SECURE STAKING OF THE ROLL IN A TRENCH, 3"-5" DEEP, DUG ON CONTOUR.
2. RUNOFF MUST NOT BE ALLOWED TO RUN UNDER OR AROUND ROLL.

STRAW WATTLES



APPROVED

 PUBLIC WORKS DIRECTOR

DATE
 2/14/22

REVISIONS	DATE	DRAWN	DESIGNED

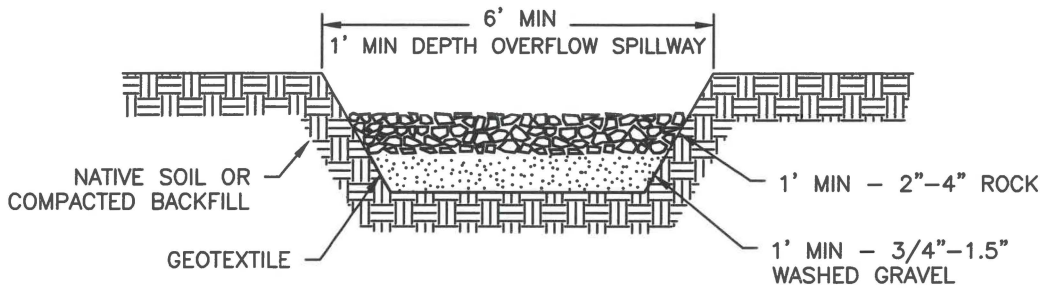
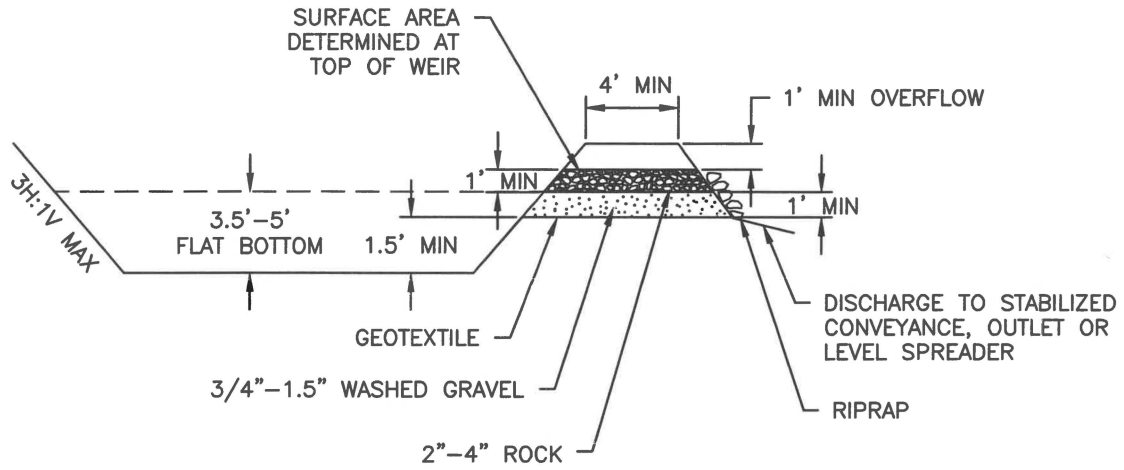

NOTES:

1. SEDIMENT TRAP MAY BE CONSTRUCTED BY EXCAVATION OR BY BUILDING A BERM.
2. OUTFLOW CHANNEL SHALL BE CONSTRUCTED BY EXCAVATION.
3. SEDIMENT TRAPS SHALL BE LIMITED TO SITES OF LESS THAN 1-ACRE. FOR ANY SITE GREATER THAN 1-ACRE, SEE SEDIMENT BASIN.
4. SEDIMENT SHALL BE REMOVED BEFORE 1' ACCUMULATES.

SEDIMENT TRAP



APPROVED

 PUBLIC WORKS DIRECTOR

2/14/22
 DATE

REVISIONS	DATE	DRAWN	DESIGNED

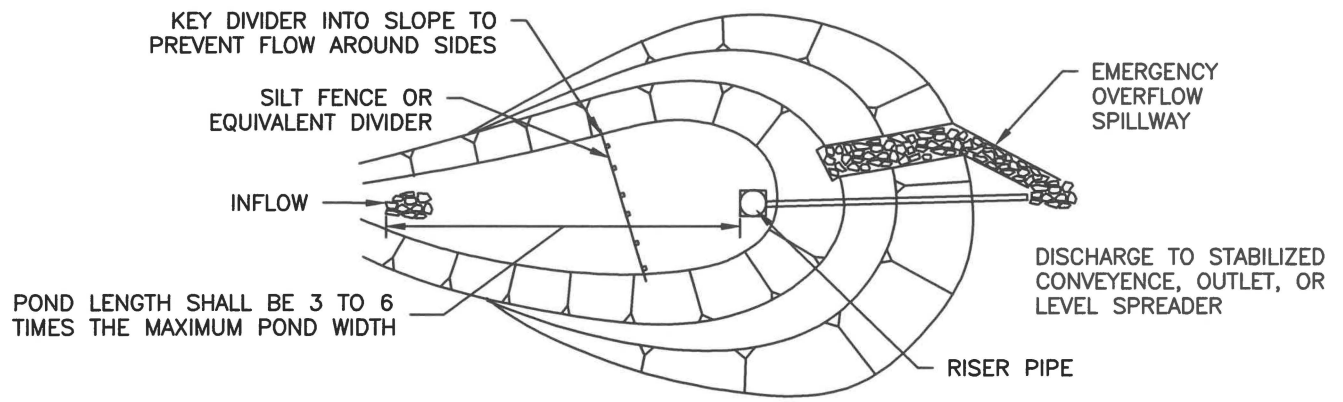

PLAN VIEW

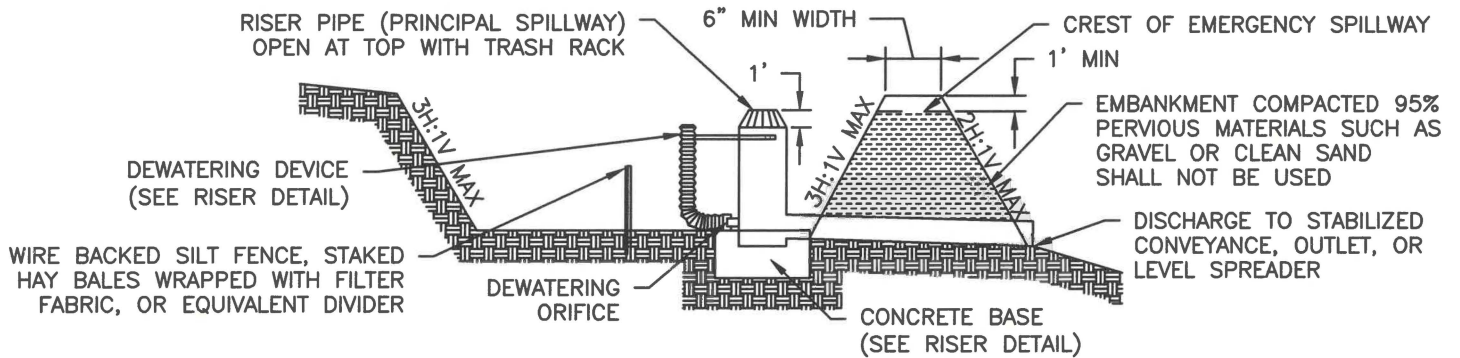

CROSS SECTION

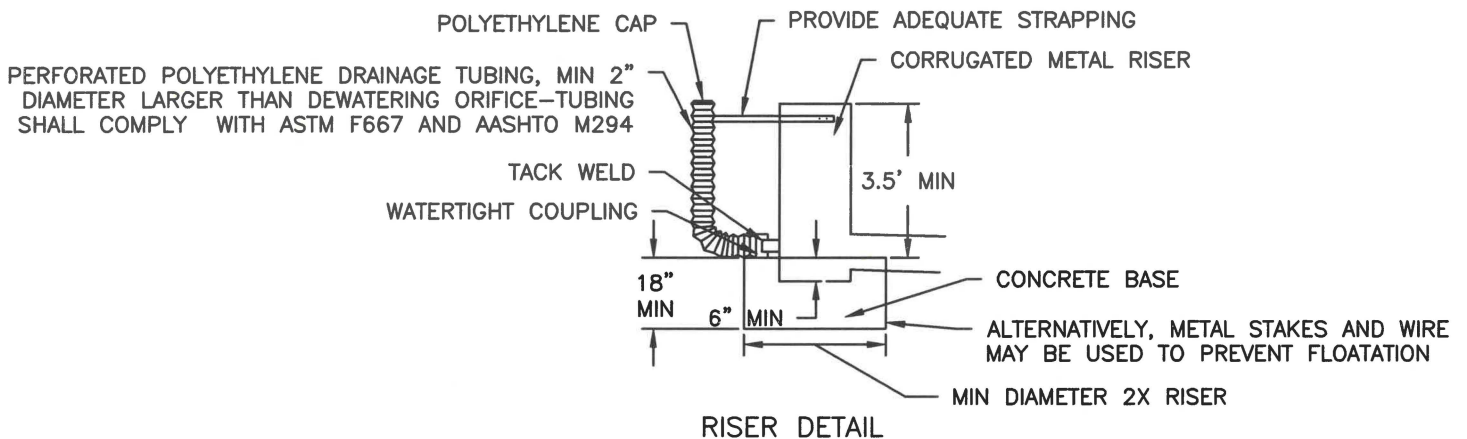

RISER DETAIL

NOTES:

1. STRUCTURES HAVING A MAXIMUM STORAGE CAPACITY AT THE TOP OF THE DAM OF 10 ACRE-FT (435,600 FT³) OR MORE ARE SUBJECT TO THE WASHINGTON DAM SAFETY REGULATIONS (CHAPTER 173-175 WAC).
2. GRADE BOTTOM OF BASIN AS LEVEL AS POSSIBLE.
3. SPILLWAY SHALL BE LINED WITH 2"-4" ROCKS.
4. ALL INLETS AND OUTLETS SHALL BE PROTECTED WITH RIPRAP.
5. POND MAY BE FORMED BY BERM OR BY PARTIAL OR COMPLETE EXCAVATION.
6. IF THE POND POSES A SAFETY HAZARD, IT SHALL BE FENCED.
7. REMOVE SEDIMENT BEFORE 1-FOOT ACCUMULATES.



APPROVED

 PUBLIC WORKS DIRECTOR

SEDIMENT POND

REVISIONS	DATE	DRAWN	DESIGNED
214172			

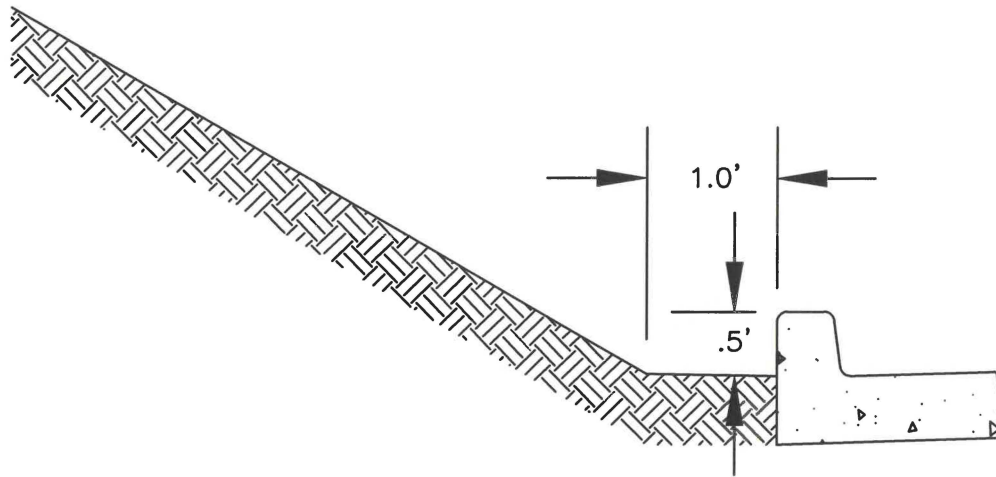

NOTES

1. SILTATION TRENCH BEHIND CURB ALLOWED IN REPLACE OF SILT FENCE OR OTHER BARRIER WHERE FEASIBLE.
2. REMOVE SEDIMENT AS NEEDED TO MAINTAIN A MINIMUM OF 0.5" LIP.

SILTATION TRENCH BEHIND CURB

APPROVED

[Signature]
 PUBLIC WORKS DIRECTOR

2/14/22
 DATE

REVISIONS

DATE

DRAWN

DESIGNED

